

CNC Production for Professionals

PRO-MASTER 7017 | 7018



PRODUCTIVITY AND PRECISION



C. DAHM
MASKINFORRETNING AS

Nordåsdaalen 10, 5235 RÅDAL- BERGEN
Tlf 55 11 24 70 Fax 55 11 24 71
firmapost@dahm.no
www.dahm.no



High Efficiency Drilling and Formating Center

The PRO-MASTER 70 series from HOLZ-HER makes it easier than ever to decide in favor of efficient CNC technology. The 70 series offers rational machining and a high level of flexibility especially for production of case parts. This well-thought-through concept offers solutions for all applications – choose the right model for your application. State-of-the-art safety concepts give you the choice between patented 3-field foot mats, safety bumpers or light grids. This allows you to match the HOLZ-HER machining centers individually and reliably to your operating situation.



PRO-MASTER 7017 with safety bumper.



Enormous Creativity

Awake the Potential of the
PRO-MASTER 70 Series

- High equipment level with six consoles, drilling head with grooving saw, positioning laser and tool changer as standard features.
- Edge routing and drilling up to max. 3,540 x 1,287 mm as well as 5,340 x 1,287 mm on the 500K version (minus radius of cutter).
Actual machining height 180 mm.
- User-friendly software as complete package with CAMPUS machine and office license.
- Spindles with ceramic bearings for efficient and precise milling and formatting.
- 11 kW power spindle and C-axis for even higher performance (optional on 7017).
- Precision direct drives with exceptionally high dynamic acceleration values for extremely high productivity.



Illustrations may contain optional features.

Coordinated Performance Profile

■ Tool Changer

12-position traveling disk tool changer for effective pendular processing as standard equipment on the PRO-MASTER 7017 performance and 7018 premium (Fig. 1). Options include an 18-position disk tool changer or a 12-position pick-up tool changer for highly varying tools.

■ Machining Head

Powerful spindle with ceramic bearings and drilling head with integrated grooving saw (Fig. 2); including fully interpolating C-axis on PRO-MASTER 7018 premium and integrated torque support for changeover units on 7017 (C-axis optional).

■ Linear Guides

High precision ground linear guides with steel strip cover on all moving axes. Extremely long service life and smooth operation, backed up by HOLZ-HER's 10 year guarantee (Fig. 3).

■ Universal Clamping Systems

A variety of suction cups and frame clamps available for processing panels and solid wood as well as an actual working height of 180 mm ensure an enormous range of application for HOLZ-HER's 70 series (Fig. 4).

■ Lock Case Cutter

A powerful 5.6 kW motor on the optional horizontal cutter unit makes the PRO-MASTER 7018 the absolute machine for professional door production. HOLZ-HER also offers a wide matching selection of reliable, high performance changeover units for all types of applications (Fig. 5).

■ Variable Safety Concepts

Depending on your operating situation you can choose freely between light grids and 3-field foot mats or safety bumpers for highly efficient pendular processing.



1



2



3



4



5

Illustrations may contain optional features.

HOLZHER

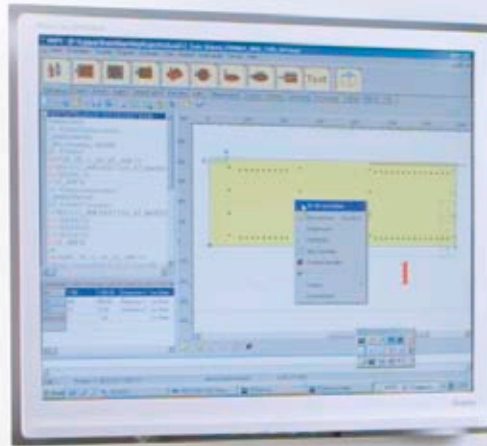

CONTROL

The CAMPUS Control – Provides clear Arrangement and absolute Convenience

Our high quality, user-friendly HOLZ-HER machine control system is an integral part of the machine's design. The equipment package includes CAMPUS/NC Hops with office and machine license and full-fledged aCADemy CAD software. The integrated CabinetControl Base furniture designing software rounds out this premium package. This offer provides the prerequisites for effective machining and convenient operation with bar code interface, manual control unit, import features and much more.



The intelligent energy management for HOLZ-HER CNC machining centers.

CAMPUS – with integrated CabinetControl Base Software

- CAMPUS aCADemy is a full fledged, high-performance CAD/CAM software package with versatile import features.
- In addition to variable programming, 3D views and simulations, the NC Hops editor offers full Z-axis interpolation and a text editor.
- »Easy Snaps«, adjustable parameters and well-conceived macros additionally simplify and speed up program control.
- The Workcenter shows the occupancy of the machine table. Tools, drilling heads and routes are automatically optimized over the workpiece as a whole and the machining times are calculated.
- The MT Tool Manager allows clear, graphic set-up using »Drag & Drop«.
- 3D simulation module with integrated processing simulation.
- Open software architecture allows simple incorporation of existing data and connection to a wide range of branch, design and CAD/CAM software.

CabinetControl – Software for simple Furniture Designing

- CabinetControl Base included in software package.
- Design of furniture.
- Views can be represented in 2D or 3D.
- Quick adaptation to individual desires of furniture buyers.
- Perfect presentation of furniture.
- Automatic completion of cutting plans.
- Generates CNC machining program automatically at the touch of a button.
- Can be upgraded to full version of CabinetControl with greater range of features – ask us!

CabinetControl
can be downloaded from
www.holzher.com



Highly efficient Production in combination with other HOLZ-HER Machines

Programming – Sawing – Edgebanding – CNC Machining



CabinetControl (1)

- Design component at the click of the mouse.
- Automatic generation of cutting lists and CNC programs.

Rational and Precision Sawing (2)

- Perfect cutting results.
- Mature optimization software.
- Optimum sawing cycle.

Intelligent Edgebanding (3)

- Program selection at the touch of a button.
- Alternative: Fully automatic with barcode.

Perfect Data Flow (4)

- Program information also via data matrix barcode.

Effective CNC Performance (5)

- Automatic program call with barcode.
- Variable programming with CAMPUS Software.
- Perfect cutting results.

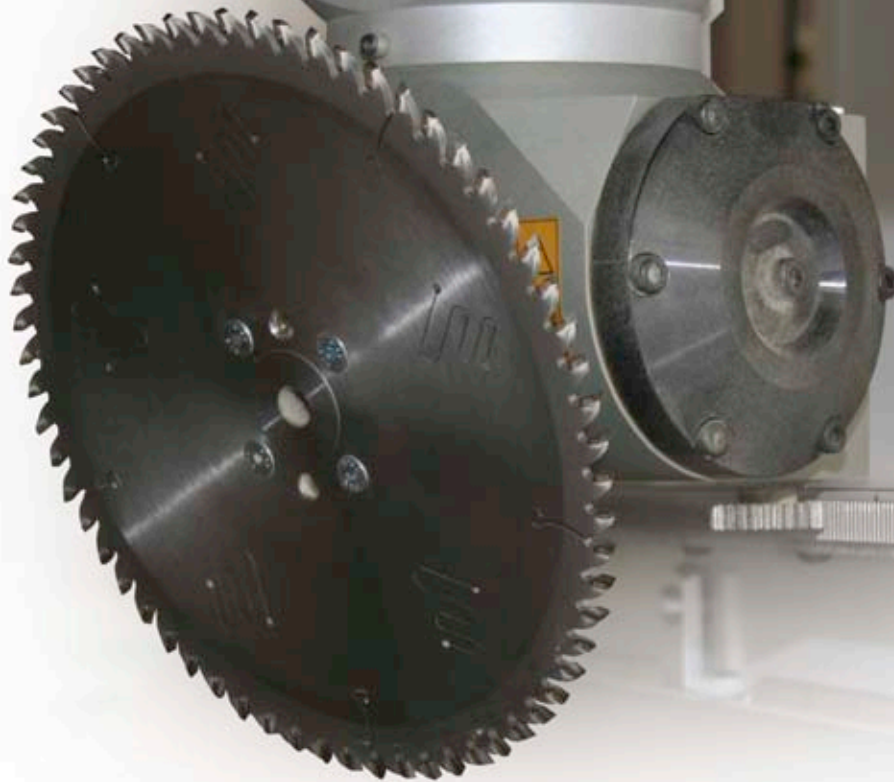

VARIO5 – ANGLES WITHOUT RACKING YOUR BRAINS

The high performance All-Round Talent

Your choice – perfectly matched to your requirements as PRO-MASTER 7017 classic and performance or the more powerful version – the PRO-MASTER 7018 premium.

- Powerful cutter units with ceramic bearings, guided by directly driven, high precision servo-motors with absolute sensors for enduring precision.
- Three precise and dynamically controlled axes on the PRO-MASTER 7017 – can be upgraded to include a fully interpolating C-axis.
- Four axes as standard features on the PRO-MASTER 7018 premium – all axes fully interpolating for maximum flexibility.
- The optional Vario5 unit takes the horror out of angles and miters – simple to program, the cutting angle is adjusted fully automatically under CNC control ensuring absolute precision (prerequisites: C-axis and pneumatic interface).
- Can be upgraded with a large selection of high quality, long life changeover units for highly varying applications.
- The comprehensive basic equipment and mature solutions ensure enormous versatility for a wide variety of special applications.
- With 180 mm from the top of the suction cups, the 70 series from HOLZ-HER offers the maximum working height in its class.

Illustrations may contain optional features.

Machining Head – equipped for all Requirements

An L-shaped drilling head with 24 spindles, a grooving saw and powerful 3 kW motor are standard features on the PRO-MASTER 7018 premium. With the PRO-MASTER 7017 you can choose between a drilling unit with 16 spindles or a special drilling head with 24 spindles for production of furniture (Fig. 1).



Contour Laser – the complete Positioning Solution (optional)

Makes positioning suction cups, frame clamps and workpieces easy as pie. With the contour laser it is easy to project even complex workpiece contours (Fig. 2).

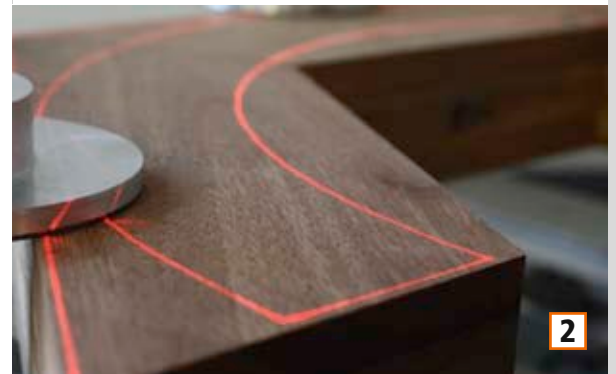

Powerful. Dynamic. Innovative.

Complex Applications made easy

Production of highly varying types of furniture as custom or series pieces, staircases, doors, etc. – the equipment package on the PRO-MASTER 7017 / 7018 offers the right solution for every application.



Equipment Overview

| Machine | PRO-MASTER 7017 classic | PRO-MASTER 7017 performance | PRO-MASTER 7018 premium | Options |
|-------------------------------------|---|---|---|--|
| Machining dimensions (edge routing) | In X = 3,540 mm, in Y = 1,287 mm (minus cutter radius) | In X = 3,540 mm, in Y = 1,287 mm (minus cutter radius) | In X = 3,540 / 5,340 mm, in Y = 1,287 mm (minus cutter radius) | |
| Cutter unit | 6.5 kW, ceramic bearings, 1,000 – 18,000 rpm * | 6.5 kW, ceramic bearings, 1,000 – 18,000 rpm * | 11 kW, ceramic bearings, 1,000 – 24,000 rpm* | * 11 kW air or liquid cooled, 1,000 – 24,000 rpm |
| Vector speed | 100 m/min. | 100 m/min. | 100 m/min. | |
| Protection equipment | Light grid (1-field machining)* | 3-field footmat (pendular machining)* | 3-field foot mat (pendular machining)* | * Safety bumper |
| Workpiece support | 6 Consoles incl. 8 stops, laser pointer* | 6 Consoles incl. 8 stops, 4 charging aids, laser pointer | 6 Consoles incl. 8 stops, 4 charging aids, laser pointer | * 4 charging aids |
| Drilling head | 14 Spindles (10 V 4 H)*, incl. sawing unit for grooving in X-direction | 14 Spindles (10 V 4 H)*, incl. sawing unit for grooving in X-direction | 24 Spindles (18 V 6 H), incl. sawing unit for grooving in X-direction | * 24 Spindles (18 V 6 H) |
| Workpiece clamping | 100 m³/h low maintenance, dry-running type vacuum pump* | 100 m³/h low maintenance, dry-running type vacuum pump* | 100 m³/h low maintenance, dry-running type vacuum pump* | * 140 m³/h Vacuum pump 250 m³/h Vacuum pump |
| Tool changer | 12-position pick-up tool changer with tool cover* | 12-position traveling disk tool changer** | 12-position traveling disk tool changer** | * 12-position traveling disk tool changer ** 18-position disk tool changer, 12-position pick- up tool changer with tool cover |
| Software | Campus software package incl. aCADemy CAD/CAM module with machine and office license and CabinetControl Base | Campus software package incl. aCADemy CAD/CAM module with machine and office license and CabinetControl Base | Campus software package incl. aCADemy CAD/CAM module with machine and office license and CabinetControl Base | |

Optional

Included as
standard feature



TECHNICAL DATA

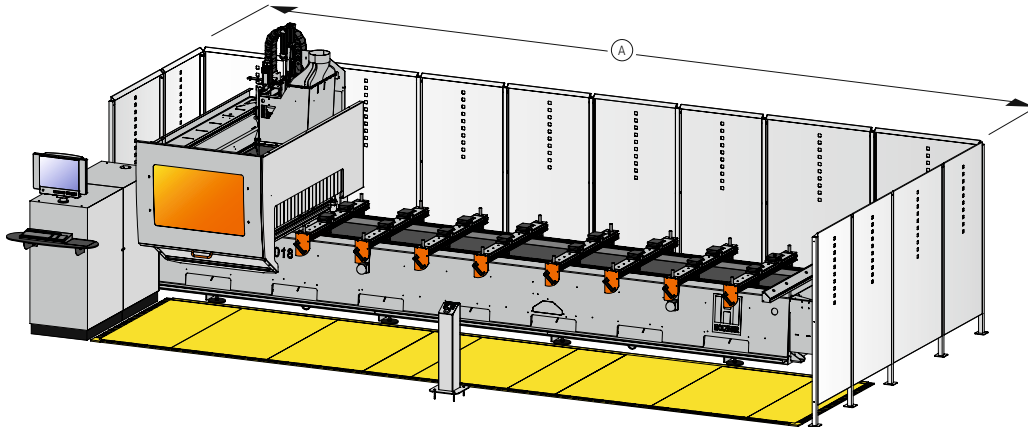

Control cabinet on left-hand side of machine
(short version)

| Machine dimensions | PRO-MASTER 7017 7018 320 | PRO-MASTER 7018 500 |
|-----------------------|----------------------------|---------------------|
| Overall length A (mm) | 6,118 | 8,220 |
| Weight (kg) | 3,500 | 4,300 |

■ Light barrier field (classic)
■ 3-field foot mat (performance)

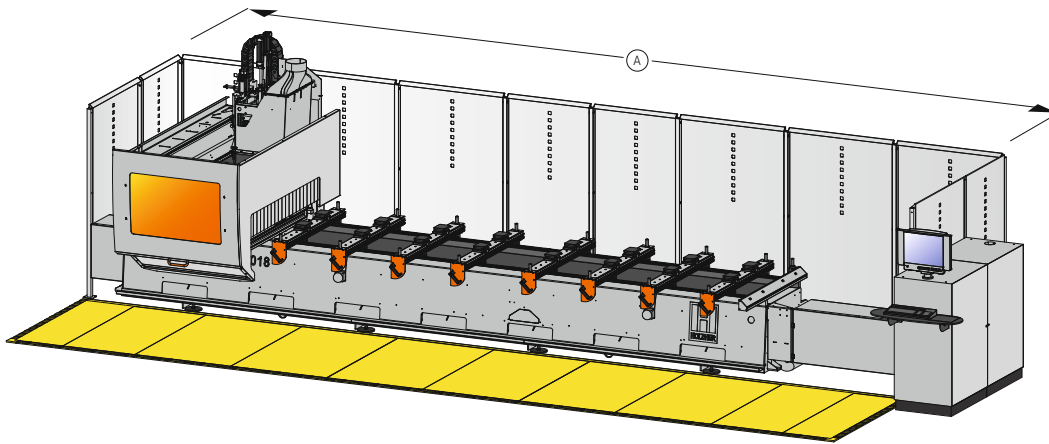

Control cabinet on right-hand side of machine
(standard version)

| Machine dimensions | PRO-MASTER 7017 7018 320 | PRO-MASTER 7018 500 |
|-----------------------|----------------------------|---------------------|
| Overall length A (mm) | 7,200 | 9,280 |
| Weight (kg) | 3,500 | 4,300 |

■ Light barrier field (classic)
■ 3-field foot mat (performance)

Product brochures and many
videos are available at
www.holzher.com

The technical data specified is intended for reference only. HOLZ-HER wood-working machines are subject to constant development and are therefore subject to modification without prior notice. The illustrations are therefore not binding. Some of the machines shown also contain special equipment not included as a standard feature. For clarity, some of the machines are shown without protective hood.

Picture credits: © istock | lisegagne, © fotolia | Alexander Rochau

UK – HOLZ-HER 3277 40 – Printed in Germany/Imprimé en Allemagne
Printed on: 04.11.2013 – First edition: 27.09.2013

Your authorized HOLZ-HER dealer

**HOLZ-HER GmbH**
Plochinger Straße 65
72622 Nürtingen
Germany
T +49 (0) 70 22 702-0
kontakt@holzher.com
www.holzher.com
HOLZ-HER
A member of the WEINIG Group