

Perfect Edging for your Products

# STREAMER



PRODUCTIVITY AND PRECISION





Optimum Price/Performance Ratio with HOLZ-HER Edging Technology

STREAMER

## Your compact Start with HOLZ-HER Edging Technology

High-tech with minimum space requirements and convincing performance spectrum for high quality edging work.

This is the basic idea behind the entire STREAMER series.

- **Processing dimensions to match large machines**  
Compact, simple and high performance: edging thickness up to 6 mm and workpiece thickness up to 60 mm.
- **Premilling cutter for perfect results**  
Including two diamond tipped cutters for perfect, single-pass processing of your panels before edgebanding.
- **Efficiency and high performance**  
Compact control for simple operation.

- **Perfect finish**  
with two, freely selectable post-processing units (scraper, glue scraper, buffing unit).
- **Always a secure joint**  
Highly flexible glue application with HOLZ-HER's **Glu Jet S** nozzle system.
- **Waterproof connections**  
You can process PUR glue just as easily as EVA glue.
- **Multi-function cutter unit**  
Including diamond tipped tool.

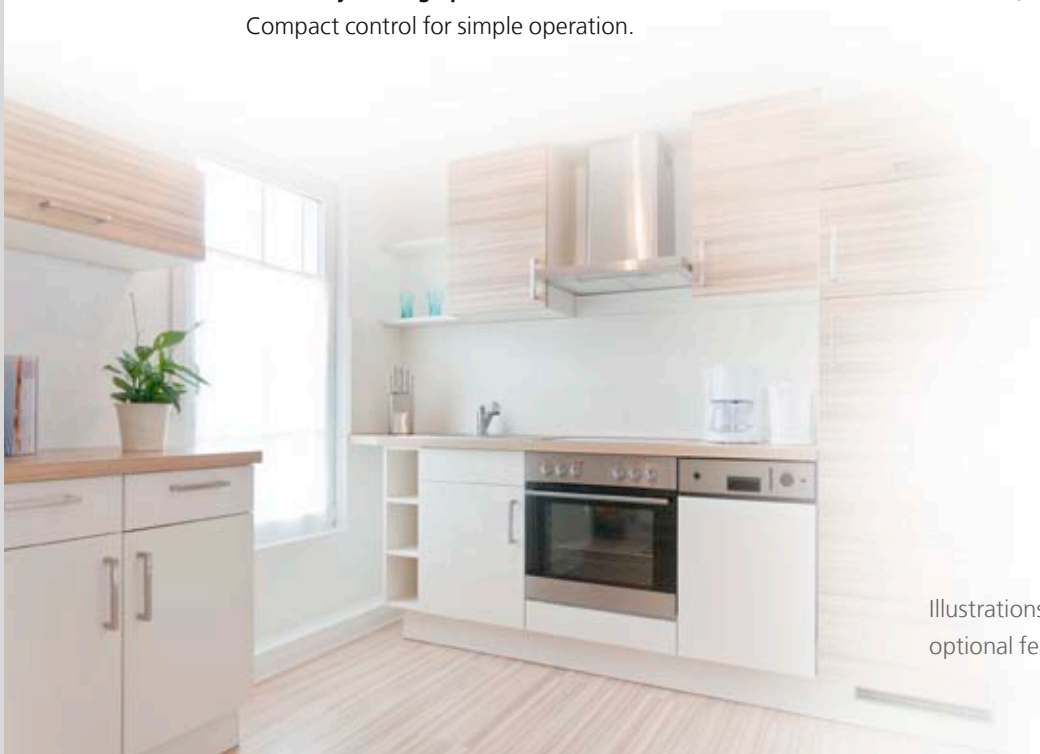

Illustrations may contain optional features.

## STREAMER 1053

- **Glu Jet S** cartridge system.
- Optionally with two finishing units.
- Work thicknesses up to 60 mm and edging thicknesses up to 6 mm can be processed with the optional 60/6-package.



## STREAMER 1054

- Including premilling cutter.
- **Glu Jet S** cartridge system.
- Optionally with two finishing units – scraper, glue scraper or buffing unit.



## STREAMER 1057

- Including premilling cutter.
- **Glu Jet S** cartridge system.
- Including corner rounding unit for complete processing.





PATENTED  
SYSTEM

GLUE APPLICATION SYSTEM

# HOLZ-HER Jet Technology for maximum Flexibility

Edgebanders are decisive for furniture with a high quality appearance. You can also profit from 50 years of HOLZ-HER technological leadership in edgebanding.

- Change over from colored to neutral glue at the flick of the wrist.
- Single cartridges or cartridge hopper (Figs. 1 and 2) – allow glue changeover in minutes.
- Changeover from EVA to PUR glue is also possible within the shortest time.
- And the entire system can also be completely cleaned in just minutes.



Heat-up time only 3 minutes



# Glu Jet S – for perfect Joints

The patented HOLZ-HER **Glu Jet S** glue application system ensures extremely short heat-up times of only 3 minutes and high strength joint connections by injecting the glue under high pressure. Moreover, it allows use of waterproof PUR glue or various glue colors as a standard feature.

Reliability, quality and experience – backed up by HOLZ-HER's three year guarantee on its patented **Glu Jet S** nozzle system.

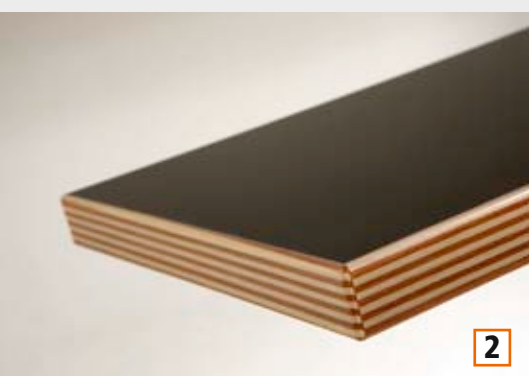
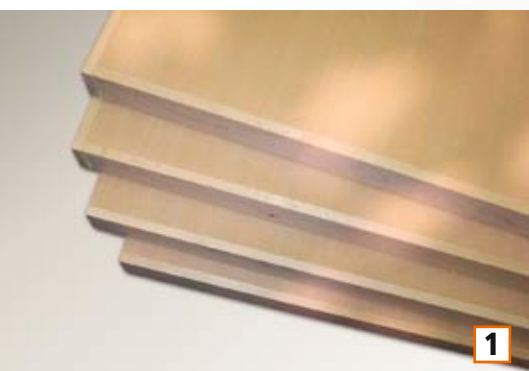

## Superior Appearance on all Materials

Starting with the state-of-the-art, high gloss edging right up to solid wood edging with cross section of 6 x 65 mm, HOLZ-HER remains unequalled for variety.

HOLZ-HER sets the trends for tomorrow today.

- Solid wood edging (Fig. 1)
- Veneer edging
- Plastic edging (Fig. 2)
- Formica edging
- Melamine resin edging
- and many others

# Perfect Edgebanding

STREAMER units offer a convincing range of performance. From premilling cutter to edging magazine, unequaled HOLZ-HER glue application system, trimming and cutting units all the way to the custom equipment in the post-machining area, numerous high performance modules are available for perfect edgebanding.

## Corner Rounding on the STREAMER 1057

Corner rounding unit for processing corners with edging thicknesses up to 3 mm. Tools for radiuses up to 3 mm and cutters up to 45 degrees – postformed profiles possible.

- Diamond tipped tool for long service life.
- Integrated chip collection in tool.
- Working height of 60 mm.

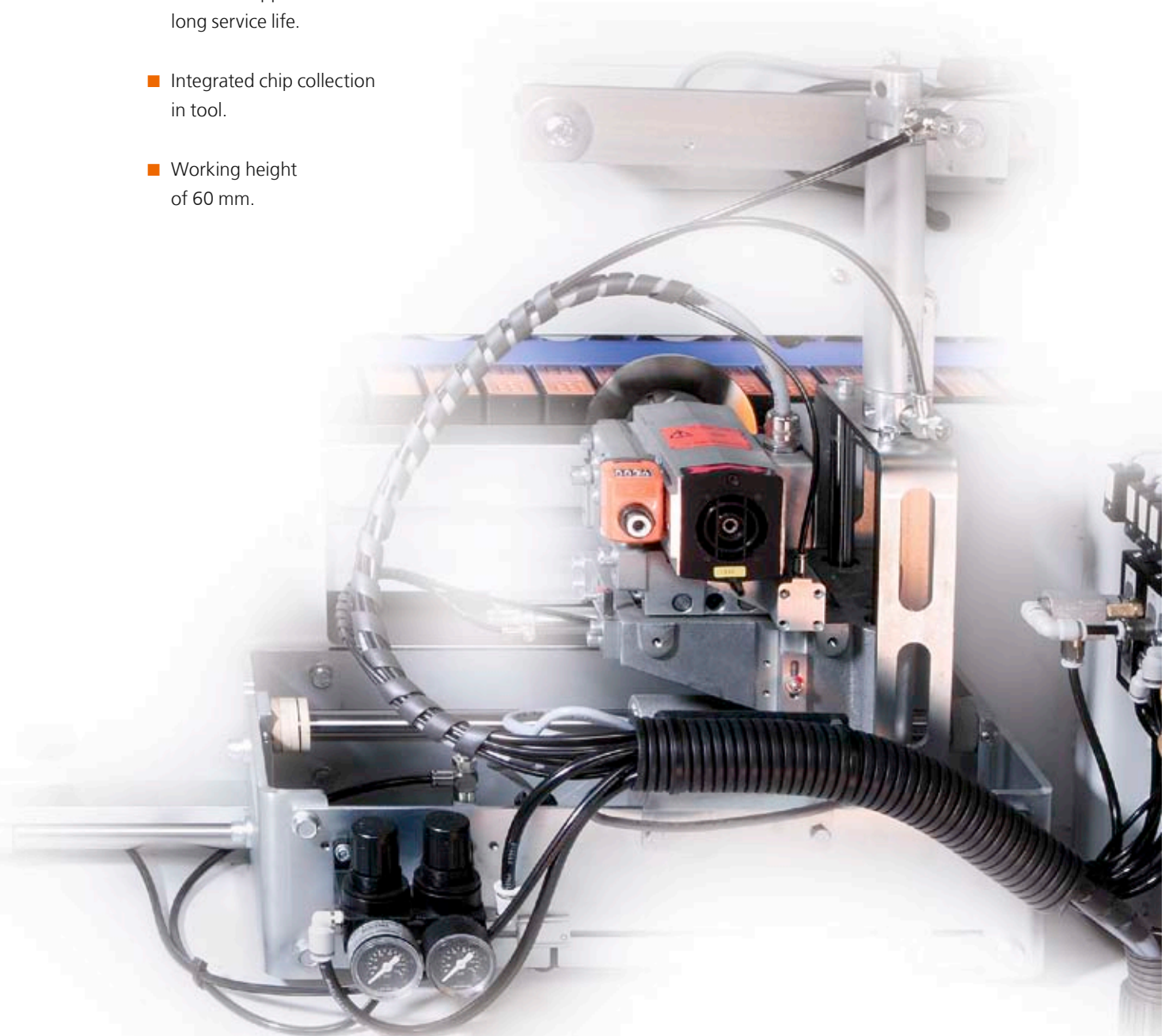



## Premilling Cutter

Cut edgings often have small tears in the top layer. The jointing cutter unit ensures perfect glued surfaces and prepares the panels for the gluing process. Equipped with ProLock quick-change flange.

Including height adjustment for optimum utilization of cutters.

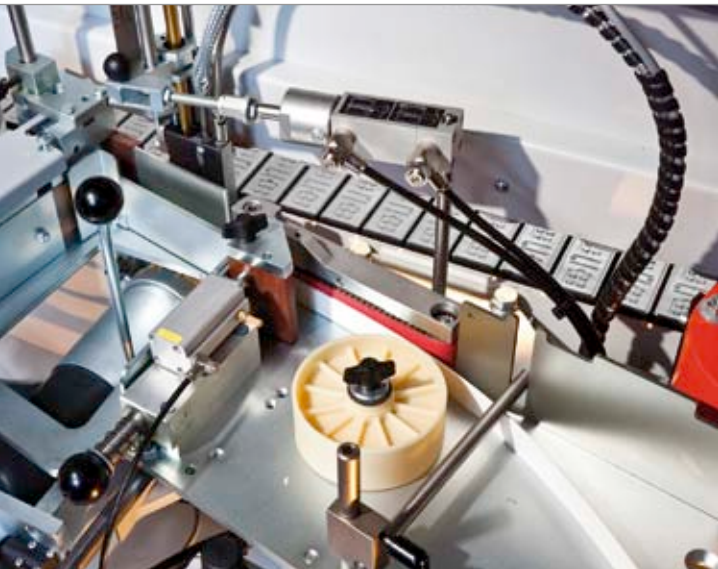
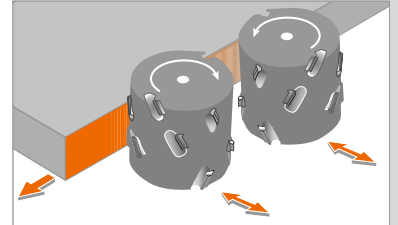

## Edging Feed

Fully automatic, user-friendly feeder for coiled edging as well as single strip feeder. An edging separator is available (as an option) for practical processing of packages of edging strips.

Gentle material handling with transport belts for edging transport and light barrier for edging recognition.

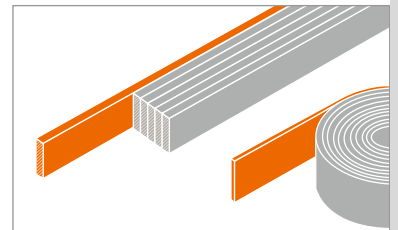

## Pressure Unit

High quality 3-roller pressure unit for pressing edging against panel cleanly and forcefully. First roller motor driven. Two conical subsequent pressure rollers.

Pneumatic, application-controlled pressure unit (optional).

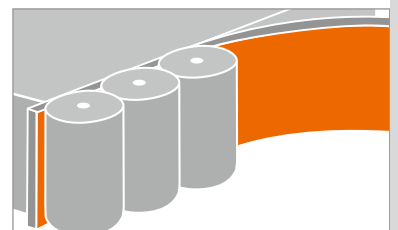



### Pneumatic End Trimming Unit (optional)

For straight or chamfered end trimming on thin edging; a standard feature allows this unit to be pivoted to 10 degrees pneumatically. High quality version with stable cast iron pillars.

Sawing motors each with two guides for precisely trimming off protruding edging.

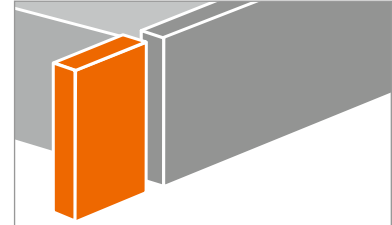

### Cutter Unit

Multi-function cutter for flush cutting on edges with thickness of up to 6 mm, radiuses up to 3 mm. Including high speed flush/radius adjustment as well as diamond tipped tools.

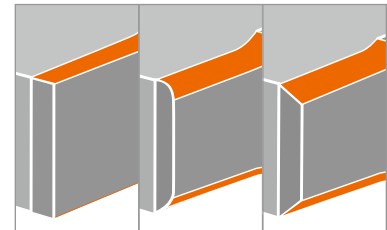

### Corner Rounding Unit

Unit for copying vertical, end edges, various edge profiles possible – including postformed profiles. Integrated chip removal. With diamond tipped tools for long tool service life.

With working height of 60 mm on STREAMER 1057.

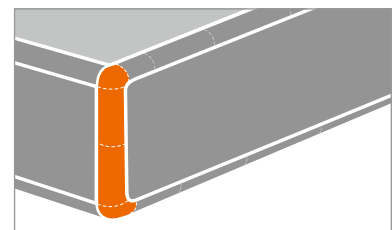





## Finishing

Perfect finishing – generous post-machining area for up to two finishing units (depending on model).

### ■ Scraper Unit

For perfect smoothing of radiuses and chamfers on plastic edging (Fig. 1).

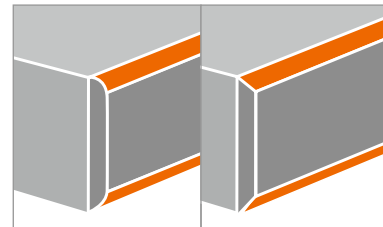

### ■ Buffing Unit

Polishing for maximum gloss; for complete finishing (Fig. 2).

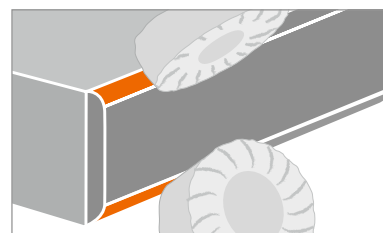

### ■ Glue Scraper



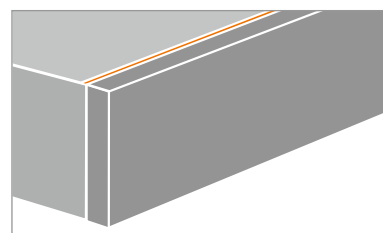

The application-controlled glue scraper removes all glue residues, which are then blown off the panel by the integrated blast nozzles (Fig. 3).



Complete Processing  
including Corner Rounding  
with STREAMER 1057

# Overview of STREAMER Series

| Machine           | STREAMER 1053  | STREAMER 1054  | STREAMER 1057  | Options   |
|-------------------|--|--|--|---|
| Control           | Compact control  | Compact control  | Compact control  |   |
| Workpiece support |  |  |  | Extends to width of 600 mm                            |
| Edge feeder       | For coiled edging or edging strips with single feeder                | For coiled edging or edging strips with single feeder                | For coiled edging or edging strips with single feeder                | Strip magazine for separating edging strips           |
| Premilling        | x  | 45 mm*   | 45 mm*   | * 60 mm   |
| Glue application  | <b>Glu Jet S</b><br>(single glue cartridge)<br>for EVA and PUR glues | <b>Glu Jet S</b><br>(single glue cartridge)<br>for EVA and PUR glues | <b>Glu Jet S</b><br>(single glue cartridge)<br>for EVA and PUR glues | Cartridge hopper                                      |
| Pressure unit     | 3 Pressure rollers, first roller driven                              | 3 Pressure rollers, first roller driven                              | 3 Pressure rollers, first roller driven                              | Controlled pneumatically by application               |
| End trimming      | Single motor 45 mm manual adjustment                                 | Single motor 45 mm manual adjustment                                 | Single motor 45 mm manual adjustment                                 | Twin motor 60 mm, with pneumatic pivot                |
| Cutting           | Multi-function 6 mm  | Multi-function 6 mm  | Multi-function 6 mm  |   |
| Corner rounding   | x  | x  | 60 mm  |   |
| Scraper           |  |  |  | Smoothing of radiuses and chamfers on plastic edgings |
| Glue scraper      |  |  |  | Insert-controlled at top and bottom                   |
| Buffing           |  |  |  | Buffing unit  |

|   |   |
|---|---|
|  | Optional  |
|  | Included as standard feature                                      |
|  | Not possible  |
|  | Free space (maximum of two post-processing units can be selected) |



## TECHNICAL DATA

|                               | STREAMER 1053 | STREAMER 1054 | STREAMER 1057 |
|-------------------------------|---------------|---------------|---------------|
| <b>Machine dimensions</b>     |               |               |               |
| Overall length (mm)           | 3,917         | 3,917         | 4,630         |
| Weight (kg)                   | 930           | 1,055         | 1,250         |
| <b>Feed rate</b>              |               |               |               |
| Feed speed (m/min)            | 10            | 10            | 10            |
| <b>Working dimensions</b>     |               |               |               |
| Minimum workpiece length (mm) | 160           | 160           | 160           |
| Workpiece thickness (mm)      | 6 – 45 (60)   | 6 – 45 (60)   | 6 – 45 (60)   |
| Edging thickness (mm)         | 0.4 – 3 (6)   | 0.4 – 3 (6)   | 0.4 – 3 (6)   |

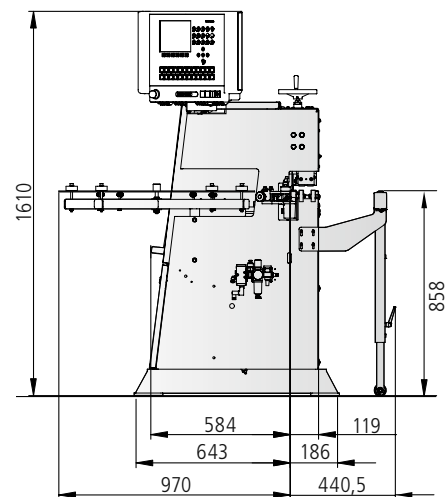
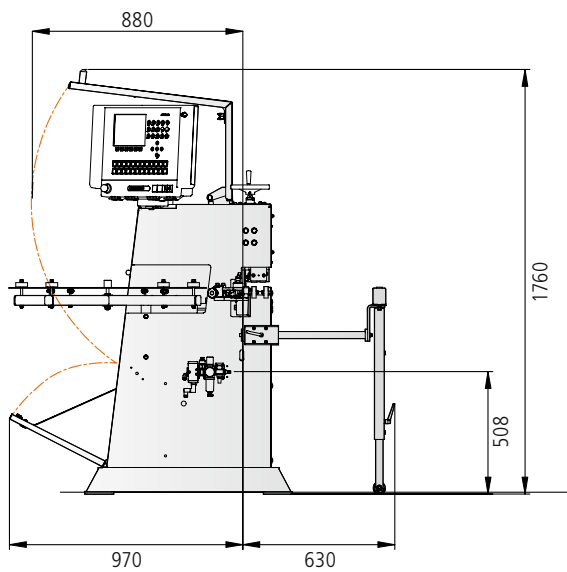

Product brochures and many  
videos are available at  
[www.holzher.com](http://www.holzher.com)

The technical data specified is intended for reference only. HOLZ-HER wood-working machines are subject to constant development and are therefore subject to modification without prior notice. The illustrations are therefore not binding. Some of the machines shown also contain special equipment not included as a standard feature. For clarity, some of the machines are shown without protective hood.

Picture credits: © istock | lisegagne, © fotolia | Alexander Rochau

**UK** – HOLZ-HER 3282 40 – Printed in Germany/Imprimé en Allemagne  
Printed on: 04.11.2013 – First edition: 27.09.2013

Your authorized HOLZ-HER dealer



**HOLZ-HER GmbH**  
Plochinger Straße 65  
72622 Nürtingen  
Germany  
T +49 (0) 70 22 702-0  
[kontakt@holzher.com](mailto:kontakt@holzher.com)  
[www.holzher.com](http://www.holzher.com)

**HOLZHER**

A member of the WEINIG Group